

KEY TO ILLUSTRATIONS

- | | | |
|--|---|--------------------------|
| 1. Play Indicator | 10. Input Selector | 17. Pause Button |
| 2. Recording Indicator | 11. Recording Level Control
(Left/Right) | 18. Record Button |
| 3. Pause Indicator | 12. Output level Control | 19. Stop Button |
| 4. Auto Rewind Switch | 13. Dolby NR/MPX Filter Switch | 20. Fast Forward Button |
| 5. Tape Counter | 14. Tape Selector Switch | 21. Playback Button |
| 6. Tape Position Indicator | 15. Eject button | 22. Rewind Button |
| 7. Dolby Indicator | 16. Rec. Mute Button | 23. Headphone Socket |
| 8. Digital Peak Meter | | 24. Power (Mains) Switch |
| 9. Microphone Sockets
(left/mono and Right) | | |

SAFETY PRECAUTION

The following precautions should be observed when servicing.

- Since many parts in the unit have special safety related characteristics, always use genuine Hitachi's replacement parts. Especially critical parts in the power circuit block should not be replaced with those of other manufactures. Critical parts are marked with \triangle in the schematic diagram, and circuit board diagram.
- Before returning a repaired unit to the customer, the service technician must thoroughly test the unit to ascertain that it is completely safe to operate without danger of electrical shock.

Note :

U	USA	FS	Switzerland and Scandinavia	C	Canada
W	General Area	BS	Great Britain	AU	Australia

SPECIFICATIONS

Semi-conductors:	
IC's	8
Transistors	18
Diodes	27
LED's	7
Track System:	4 track 2 channel
Tape:	Cassette tape (C-30, 60, 90)
Tape Speed:	4.75 cm/s
Recording System and	
Bias Frequency:	AC bias, 85 kHz
Erasing System:	AC erase
Erase Ratio :	65 dB or more (at 1 kHz)
Frequency Response:	
Normal (UD-ER)	20 Hz to 17 kHz 30 Hz to 15 kHz (±3 dB) 30 Hz to 15 kHz*
Metal	20 Hz to 19 kHz 30 Hz to 17 kHz (±3dB) 30 Hz to 17kHz*
CrO ₂ (UD-EX)	20 Hz to 18 kHz 30 Hz to 16 kHz (±3 dB) 30 Hz to 16 kHz*
FeCr	20 Hz to 17 kHz 30 Hz to 15 kHz (±3 dB) 30 Hz to 15 kHz*
S/N (Signal to Noise Ratio):	
Dolby NR OFF	58 dB (A weighted, Reference 3% T.H.D. UD-EX Tape) 57 dB*
Dolby NR ON	66 dB (A weighted, Reference 3% T.H.D. UD-EX Tape) 64 dB*

Wow and Flutter:	0.04% (WRMS) 0.13%*
Input Sensitivity and Impedance:	
Microphone	0.38 mV, 300 ohms to 5 kohms
Line in	60 mV, 100 kohms
DIN in	0.38mV, 3.3 kohms (For W, AU, BS, FS)
Output Level:	500mV or more
Output Load Impedance:	
Line out	50 kohms
DIN out	470 kohms (For W, AU, BS, FS)
Headphone	8 ohms to 2 kohms
Distortion:	Less than 1.2% (1 kHz 0 dB)
Cross Talk:	
Between tracks	60 dB (at 1 kHz) or more
Between channels	30 dB (at 1 kHz) or more
Power Supply:	
	AC 120V, 60 Hz (For U, C) AC 220V, 50 Hz (For FS) AC 240V, 50 Hz (For BS, AU) AC 100 to 110V, 115 to 127V 200 to 220V, 230 to 250V 50/60 Hz (For W)
Power Consumption:	24 W
Dimensions:	110 (H) X 435 (W) X 267 (D) mm
Weight:	6.2 kg
Motor:	Electronically controlled motor X 1 DC motor X 1
Heads:	Record/Playback Head X 1 Erase head X 1

* According to DIN 45 500

Features of Metal Tape

Metal Tape is a newly developed cassette tape, which has a magnetic material mainly composed of pure iron (Fe) on its polyester base. Compared with conventional tape which uses oxide as its magnetic material, this new cassette tape has higher magnetic retentivity and residual magnetic flux density, so it is much more effective, improving the dynamic range of cassette decks at high frequencies, increasing the max. recording level, reducing distortion, etc.

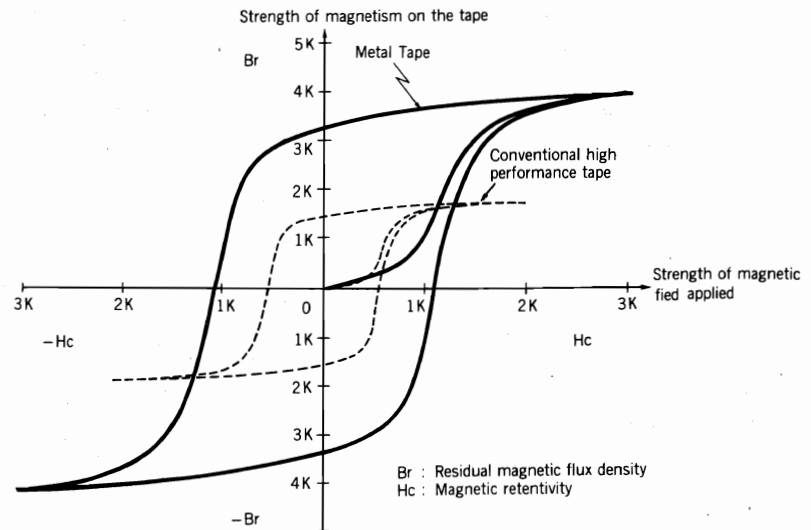

REC/PLAY/ERASE heads adapted for the metal tape

The REC/PLAY head made from Sendust alloy can generate sufficient recording bias magnetic field which matches the high magnetic retentivity of Metal Tape. The ERASE head, which has a double-gap structure using special ferrite material is used to completely erase the signal recorded on Metal Tape, so the greatly improved performance of Metal Tape can be displayed to the full.

(Reference) Recording bias current is as shown below.

Normal tape : Approx. $350\mu\text{A}$

CrO₂ tape : Approx. $450\mu\text{A}$

Metal tape : Approx. $800\mu\text{A}$

Caution :

Some Metal Tape have level fluctuations caused by peeling off of the magnetic powder, so use the magnetic tape after fully cleaning the head surface and capstan and pressure roller using alcohol.

DESCRIPTION OF NEW CIRCUIT

Fig. A

MOTOR DRIVE MODULE (TA-4030)

This unit uses 2 DC motors; a capstan drive motor (DC servo) and turntable drive motor (with mechanical governor). The capstan drive motor rotates instantaneously when power is applied. The turntable drive motor rotates when the polarity of the voltage applied to the motor is changed over by the mode control IC and power is applied. Accordingly, the direction of rotation of the motor during Fast forward, and during Rewind and take-up are reversed. Figure A shows the switching circuit of M2 for the turntable drive motor. Q4 is the switching transistor supplying +B voltage to the motor during Fast forward and Q1,

during Rewind and take-up (Record/Playback/Fast forward). Q2 is the switching transistor grounding the motor during Fast forward and Q3, during Rewind and take-up (Record/Playback/Fast forward). These transistors are OFF in the Stop mode. They are controlled by Q8, Q7 and the mode control IC during Fast forward and by Q5, Q6 and the mode control IC during Rewind and take-up (Record/Playback/Fast forward). D303 and D304 make the bias current flowing to the bases Q6 and Q7 constant, regardless of power fluctuations, to limit the current applied to the turntable motor.

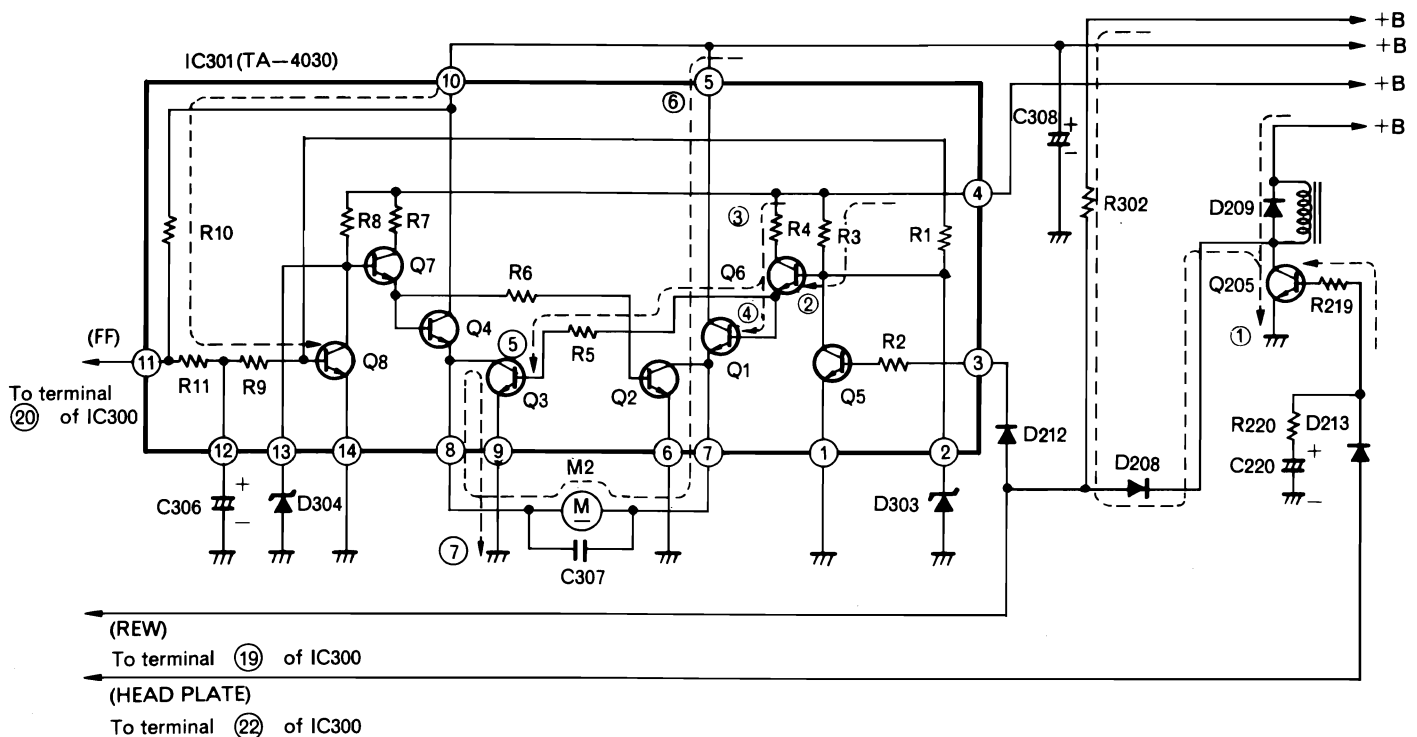
In the take-up mode, terminal ②② of IC300 is set to "High" level, Q205 turns ON and the head plate solenoid operates when the Playback button is pressed. At the same time, since the collector of Q205 is set to "Low" level, the base bias of Q5 is grounded via D208 and cut off (Dotted line ①).

When Q5 is turned OFF, Q6 is biased by R3 (Dotted line ②) and turned ON. When Q6 is turned ON, Q1 and Q3 are turned ON (Dotted line ③④⑤), and the current flows to the motor as in the direction shown with dotted lines ⑥, ⑦ and the motor starts rotating. Since terminal

①⑨ of IC300 is set to "Low" level during Rewind, Q5 is cut off, and Q6, Q1 and Q3 operate in the same way as in the take-up mode. Since terminal ②① of IC300 is set to "Low" level during Fast forward, Q8 turns OFF, Q7, Q4 and Q2 turn ON with the same operation principle as in the Rewind mode, and the current flows in the reverse direction to that during Rewind.

Note: The motor rotates in the same direction during Playback and Rewind because of its design.

DISASSEMBLY

1. Top Cover

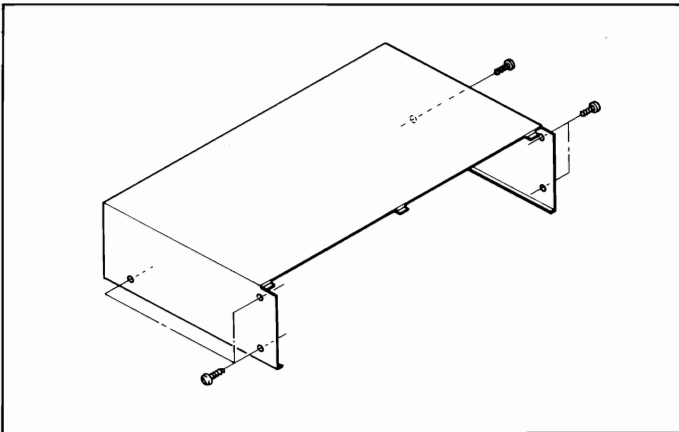

2. Cassette Lid

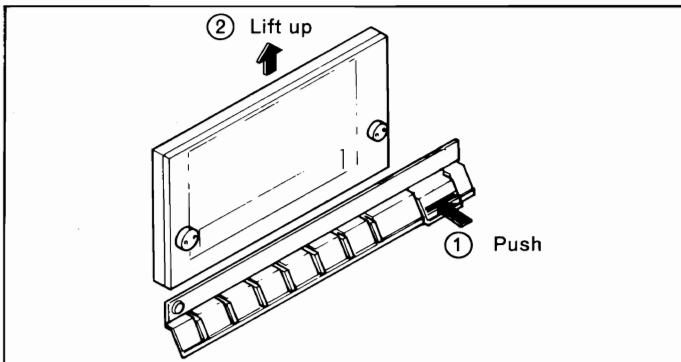

3. Front Panel

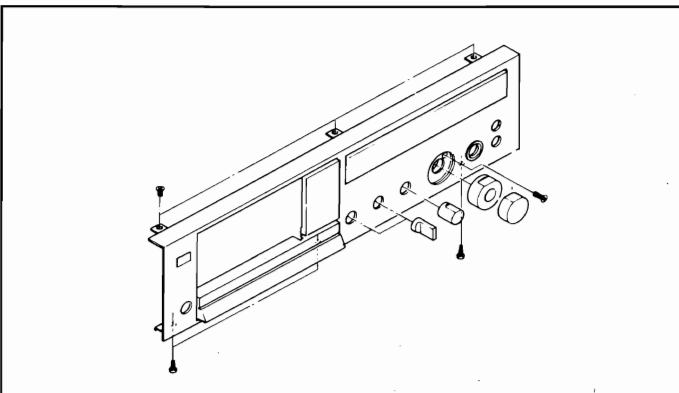

4. Control PC Board

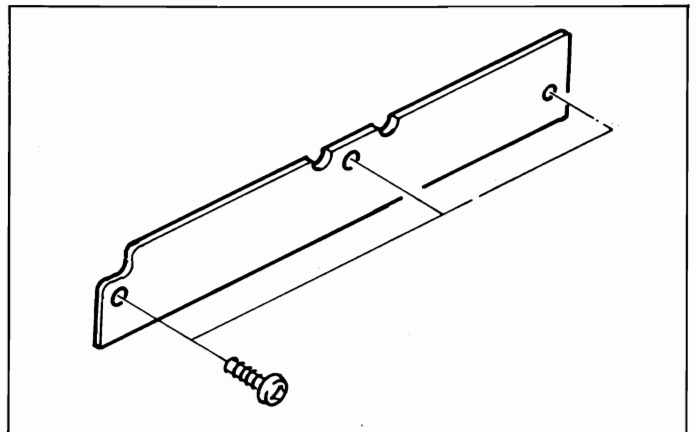

5. Indicator Holder

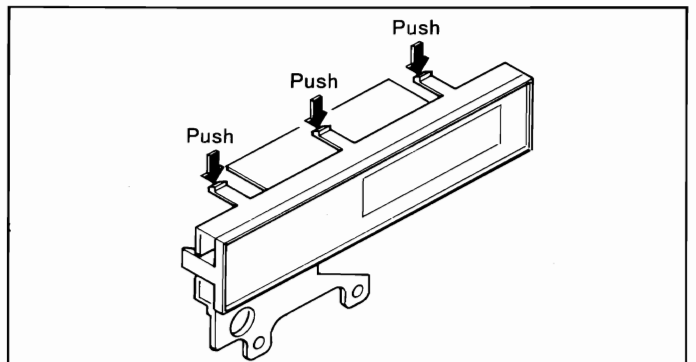

6. Power PC Board

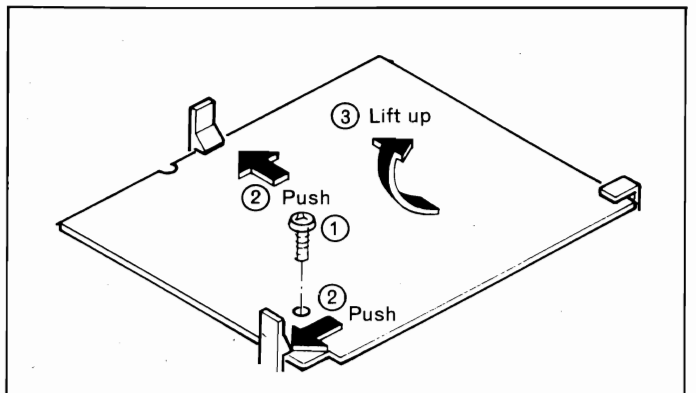

7. Main PC Board

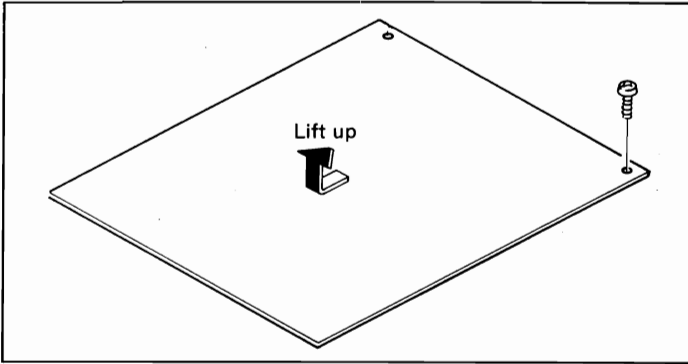

11. Cassette Metal

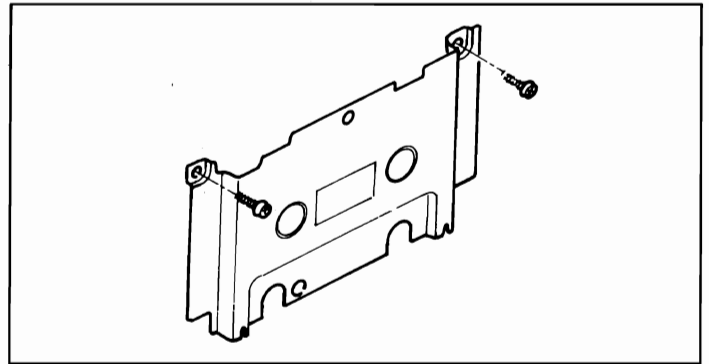

8. Chassis

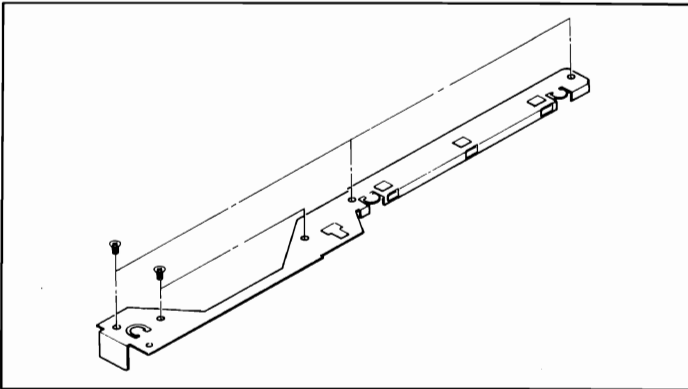

12. Flywheel Holder

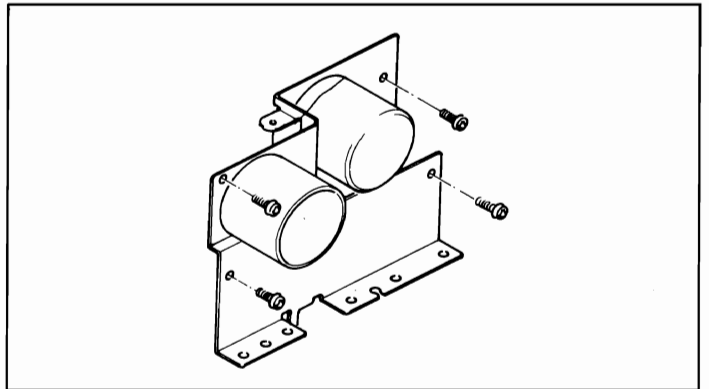

9. Cassette Chassis

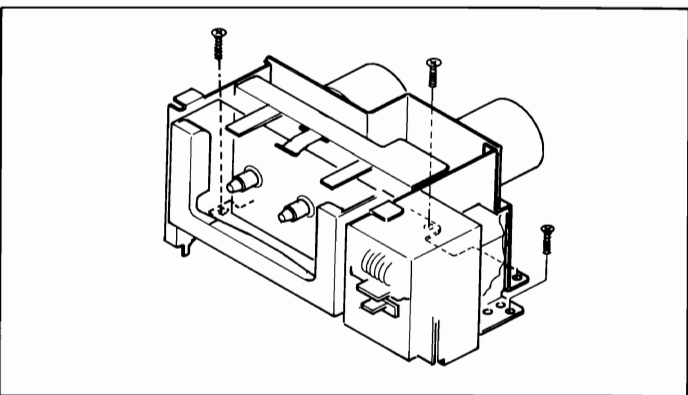

13. Solenoid Plate

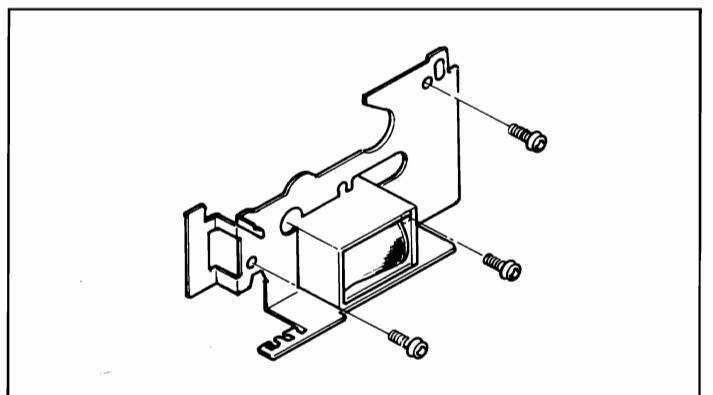

10. Bottom Cover

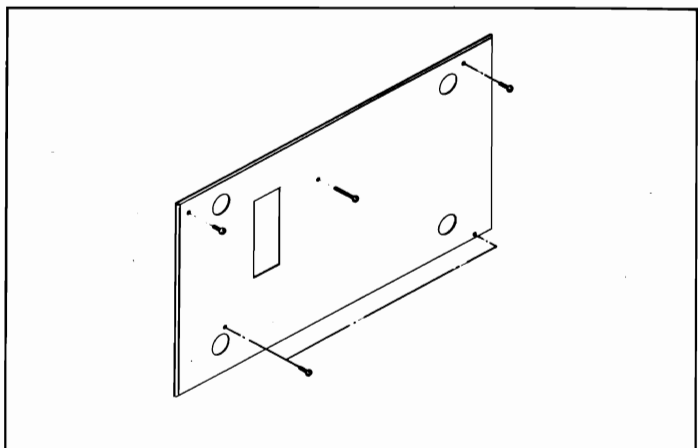

14. Counter Holder

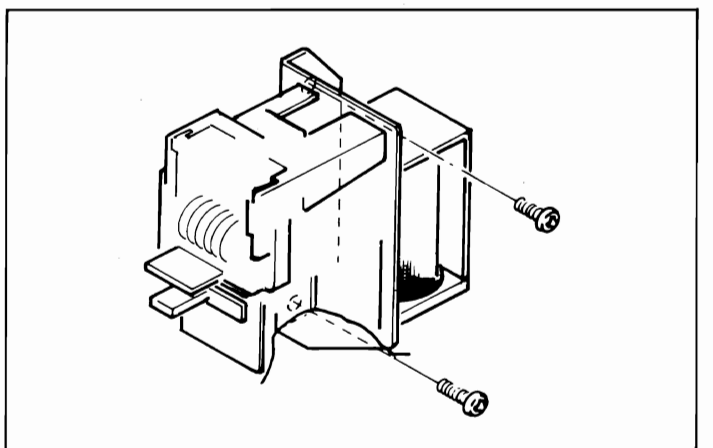

ADJUSTMENT

Perform the following adjustments in the sequence stated after cleaning the head, pressure roller, and capstan with a head cleaning stick moistened in alcohol. Also, unless specially indicated otherwise, set the switches and controls to the positions indicated in the table.

Symbol No.	Switches and Controls	Position	Symbol No.	Switches and Controls	Position
S1	DOLBY NR switch	OFF	S3	Input selector switch	LINE
S2	Tape selector switch	UD-ER (NORMAL)	RV1	Record level controls	Maximum
			RV2	Output level controls	Maximum

1. Tape speed adjustment

Setting: Playback mode

Connection

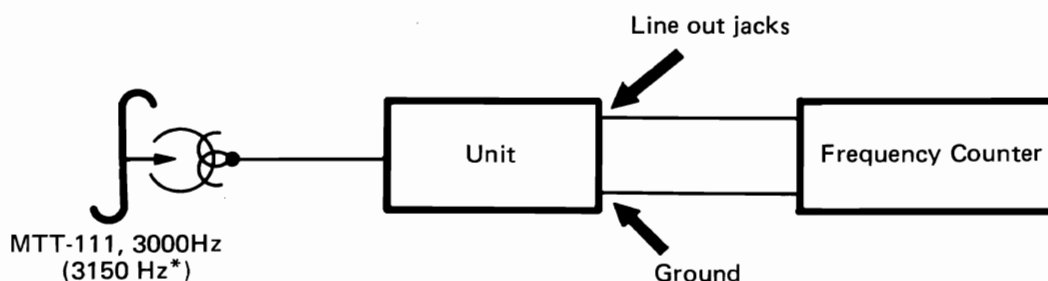

Adjustment: Warm up the unit for approximately 30 minutes; then playback test tape MTT-111, 3000 Hz (3150 Hz*) and measure the speed deviation with a frequency counter. If required, adjust the semi-variable resistor on the motor for a reading of $3000\text{Hz} \pm_{10}^{30}$ Hz (3150 Hz*). Carry out the measurement at the middle of the tape.

* According to DIN 45 500.

2. Head azimuth adjustment

Setting: Playback mode

Connection:

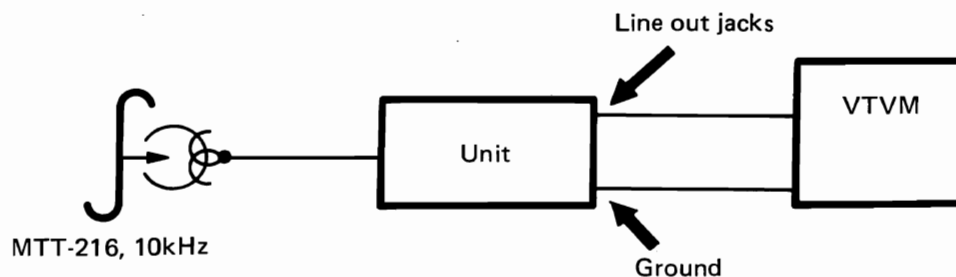

Adjustment: Playback a test tape (MTT-216, 10 kHz) and adjust the azimuth adjustment screw for maximum output.

Note: When the maximum values of both channels are different, tune to the maximum value of the L channel. In this case, the difference between the maximum values of both channels should be -2 dB or less.

3. Playback output adjustment

Setting: Playback mode

Connection:

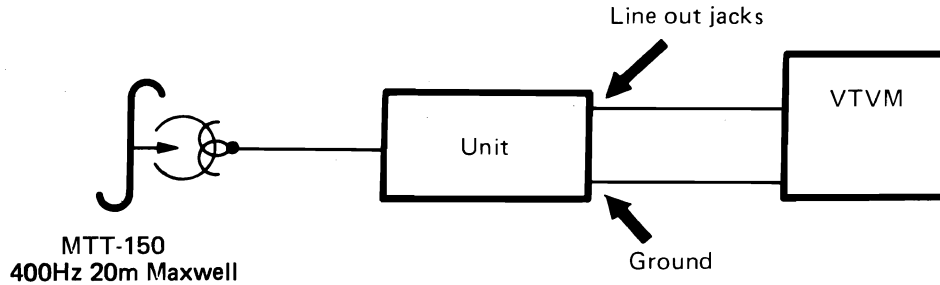

Adjustment: Playback a Dolby calibration tape (MTT-150, 400 Hz 20 m Maxwell) and adjust RT1L, R so that the voltage of Line out jack becomes 0.775V (0 dBm).

4. Adjusting the digital peak meter

Setting: Recording mode

Connection:

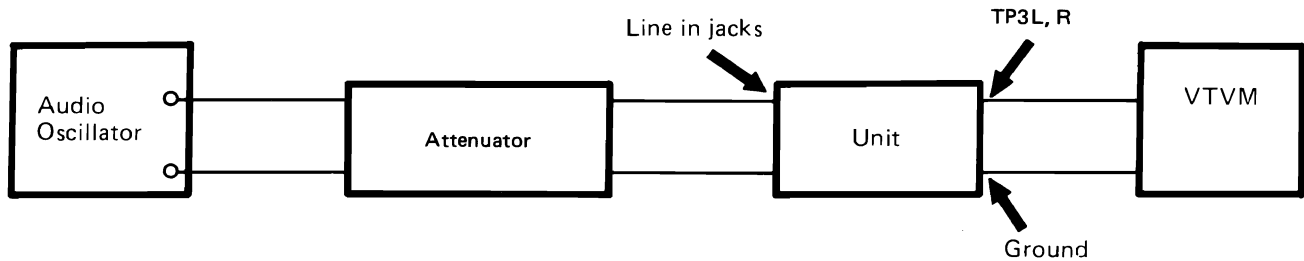

Adjustment:

- 1) Warm up the unit for approximately 30 minutes.
- 2) Set the unit to the recording mode. Apply a 1 kHz signal to the LINE IN jacks and adjust the input so that the output at TP3L, R is -3 dBm.
* Adjust the following in this mode.
- 3) Adjust MVR1L, R so that the level indicator lamp (-20 dB) of the digital FL peak meter lights when the output of the TP3L, R is -16 dBm.
- 4) Adjust MVR1L, R so that the level indicator lamp (-20 dB) of the digital FL peak meter goes off when the output of the TP3L, R is -17 dBm.
- 5) Adjust MVR2L, R so that the level indicator lamp (0 dB) of the digital FL peak meter lights when the output of the TP3L, R is -3 dBm.
- 6) Repeat adjustment items 3) to 5) a few times.

5. Bias current adjustment

Setting: Recording mode

Connection:

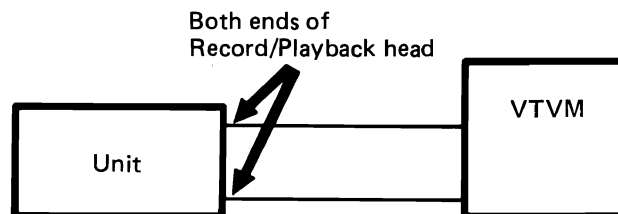

Adjustment: Set the record mode. Adjust RT5L, R so that the bias voltage of 12V is applied to the both ends of Record/Playback head.

6. Record/playback output, frequency characteristics adjustment

Setting: Recording/playback mode

Connection:

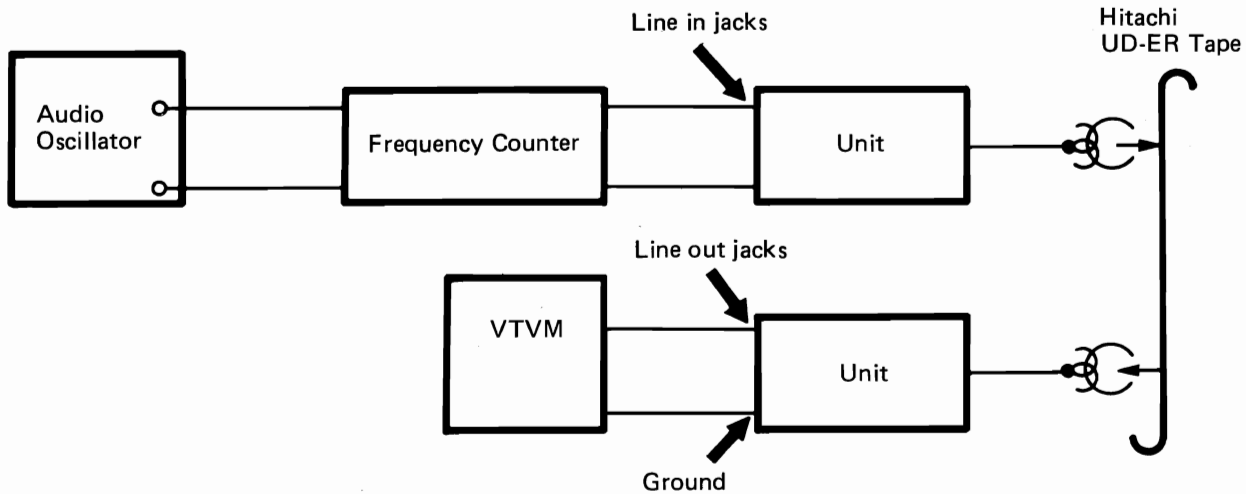

Adjustment: Set the unit to the recording mode. Apply a 1.25 kHz signal to the LINE IN jacks and adjust the input so that the output of LINE OUT jack becomes 0 dB. Next, record 1.25 kHz and 12.5 kHz signals at the level of 0 dB–20dB. Playback the recorded tape and adjust RT5L, R for an output difference within ± 1.0 dB.

7. Record/playback output adjustment

Setting: Recording/playback mode

Connection:

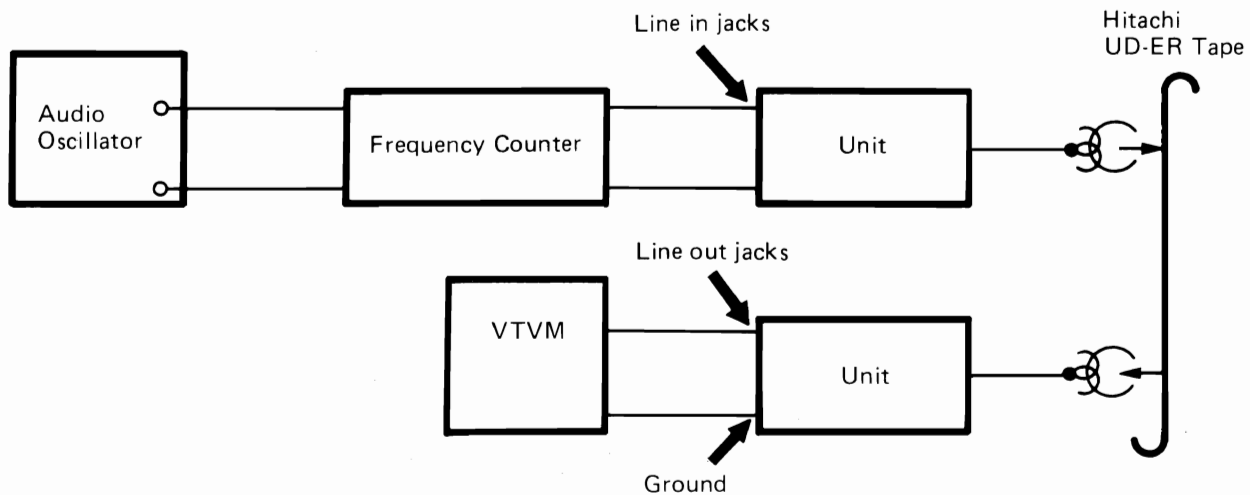

Adjustment: Record a signal of 1 kHz, 0 dB on a Hitachi UD-ER tape. Playback the recorded tape and adjust RT2L, R for a playback output of 0 dB \pm 0.5 dB.

8. Dolby NR adjustment

Setting: Recording mode

Connection:

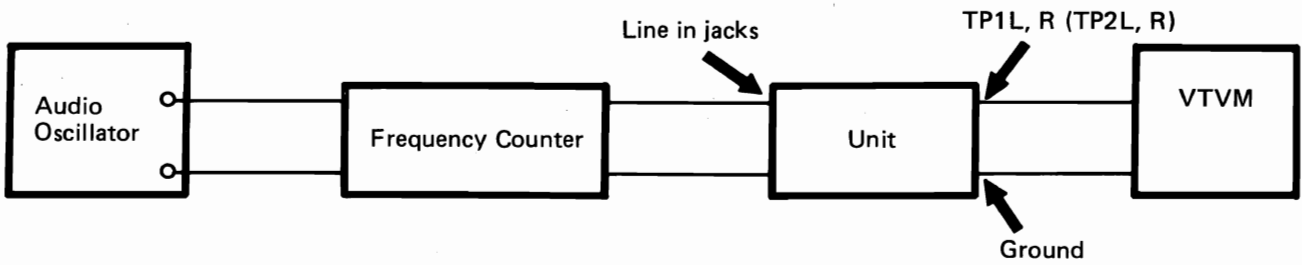

Adjustment: Set the record mode. Feed in a 5 kHz signal to the Line in jacks and adjust the input so that the voltage of TP1L, R becomes $-30.4 \text{ dBm} \pm 0.1 \text{ dB}$. Next, put the Dolby NR switch ON and adjust RT4 so that the voltage of TP2L, R becomes $-22.4 \text{ dBm} \pm 0.1 \text{ dB}$.

Adjustment Parts Location

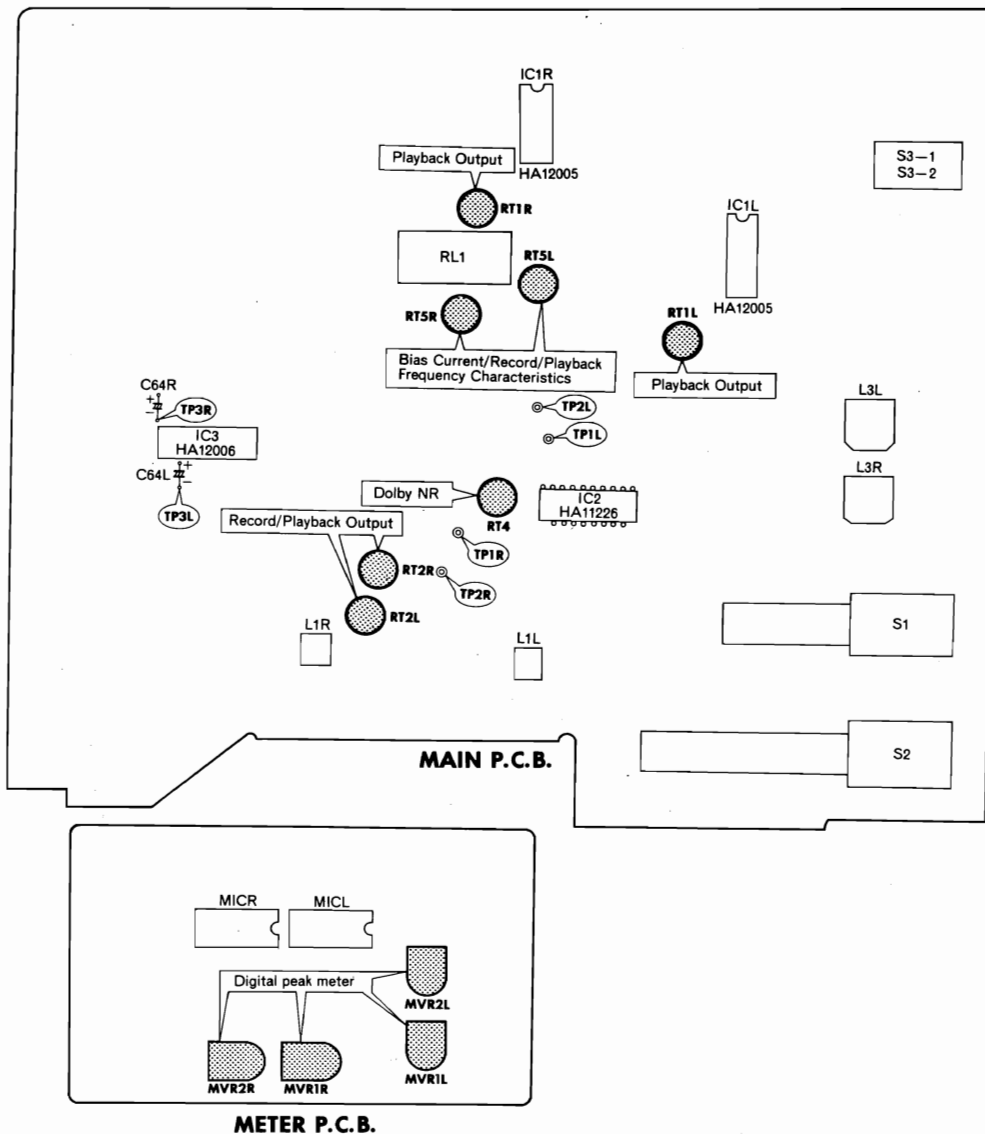

LUBRICATION

Lubricate one or two drops of machine oil to rotating point or lubricate grease to sliding point. Lubricate the respective parts listed below once every 1000 hours or once a year under normal conditions of use. Avoid oiling them excessively, or rotation may become irregular because of oil splashes.

Lubrication	
Motor shaft bearing	Oil
Capstan shaft bearing	
Pressure roller bearing	

DESCRIPTION OF NEW MECHANISM

In this chassis, electrical parts including motor, solenoid, etc. are operated by the mode control circuit.;

Electrical parts	Mode				
	PLAY	REW	FF	PAUSE	STOP
Head plate solenoid	○	×	×	×	×
Brake solenoid	×	○	○	×	×
Reel drive motor	Clockwise rotation	Clockwise rotation	Counterclockwise rotation	×	×
Capstan drive motor	○	○	○	○	○

○ shows operation mode.

× shows stop mode.

Rotation direction of the reel drive motor is that viewed from the motor pulley side.

PLAYBACK mode

When the PLAY button is pressed, the head plate solenoid operates by means of the signal from the operation control IC. P arms (A), (B) shown in Fig. B and the head plate interlocked with them shown in Fig. C slide in the direction of the arrow. By this, the next operations (1)–(3) are performed, the capstan revolves simultaneously when the power is turned ON and the reel disc drive motor revolves

clockwise simultaneously when the head plate solenoid starts, so the take-up operation starts.

- 1) The brake plate is pushed up and the brake is released.
- 2) The pressure roller is compressed against the capstan.
- 3) The take-up arm ass'y turns clockwise and is compressed against the take-up reel.

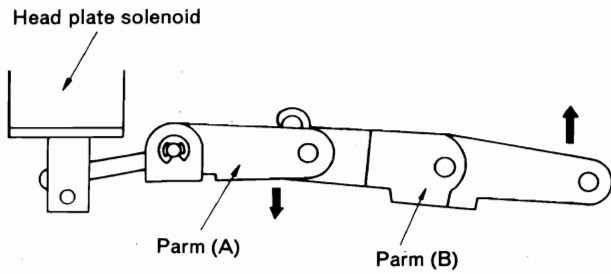

Fig. B

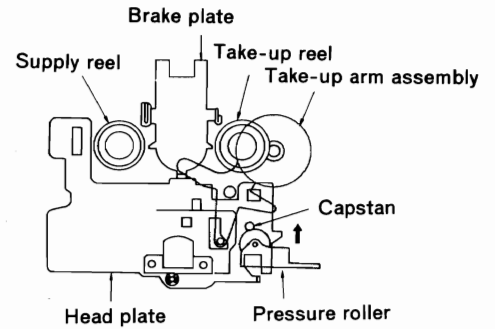

Fig. C

REW/FF mode

With the FF or REW button pressed, the FF/REW solenoid and the reel disc drive motor (FF: Counterclockwise, REW: Clockwise) operates by means of the operation control IC.

When the FF/REW solenoid operates, the FF/REW arm (A) and the brake operation arm move in the direction of the

arrow. This compresses the friction idler shown in Figs. E and F against the idler and at the same time, the brake operation arm pushes up the brake plate to release braking. By compression of the friction idler and the idler shown in Fig. E, the revolving force of the idler is transmitted to the take-up reel during FF, and to the supply reel during REW.

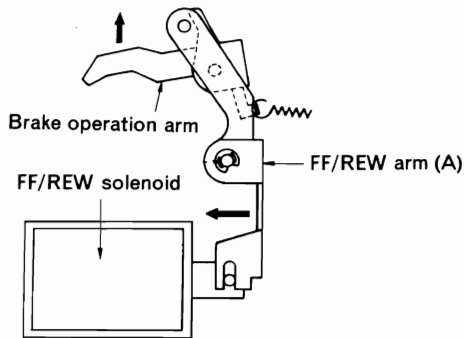

Fig. D

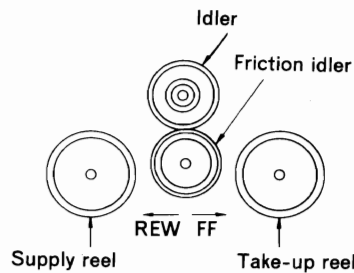

Fig. E

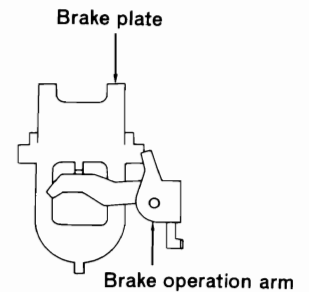

Fig. F

Inspection of mechanism

	Check item	Reference value	Remarks
1.	Pressure of pressure roller	P ₁ : 350±60 gr P ₂ : 195±34 gr	Note 1
2.	Pressure of take-up roller	150±50 gr	Note 2
3.	Turntable torque	FF	Note 3
		Rewind	
4.	Torque	Take-up	Measure in Playback mode
		FF	Measure in Fast Forward mode
		Rewind	Measure in Rewind mode
5.	Back tension	Take-up side	Less than 6 gr-cm
		Supply side	1 to 3 gr-cm
6.	Brake torque	More than 15 gr-cm	—
7.	Flywheel thrust gap	0.05 to 0.5 mm	—

Note 1 : Pressure of pressure roller

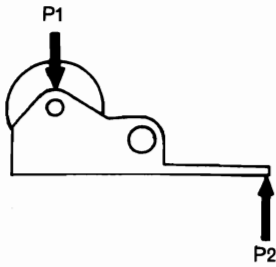

Fig. G

Note 3 : Turntable torque

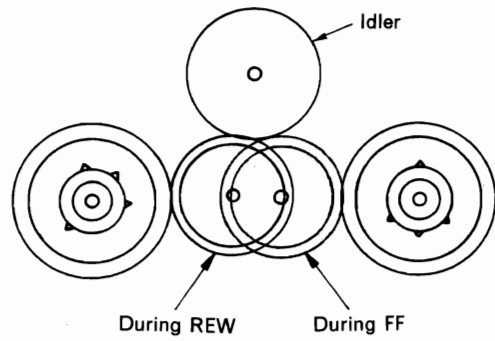

Fig. I

* The friction idler and reel disc should not slip when the reel disc stops.

Note 2 : Pressure of take-up roller

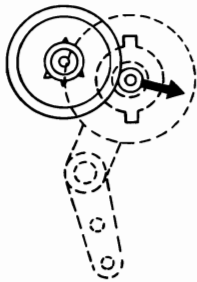

Fig. H

Installation adjustment of head plate solenoid

As shown in Fig. J, push up the head plate fully in the direction of arrow A. Push up the head plate solenoid fully

in the direction of arrow B while pulling the iron core of the head plate solenoid and fix it using 2 adjusting screws.

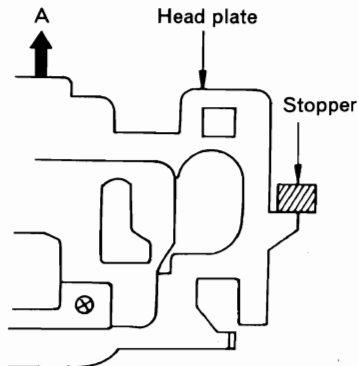

Fig. J

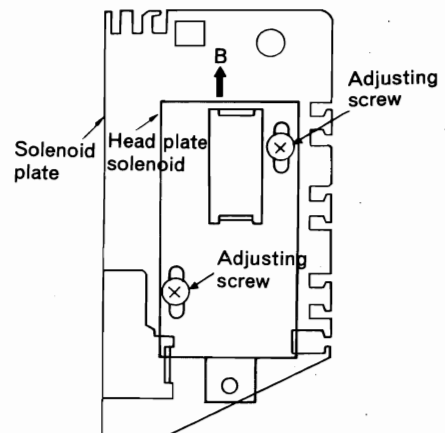
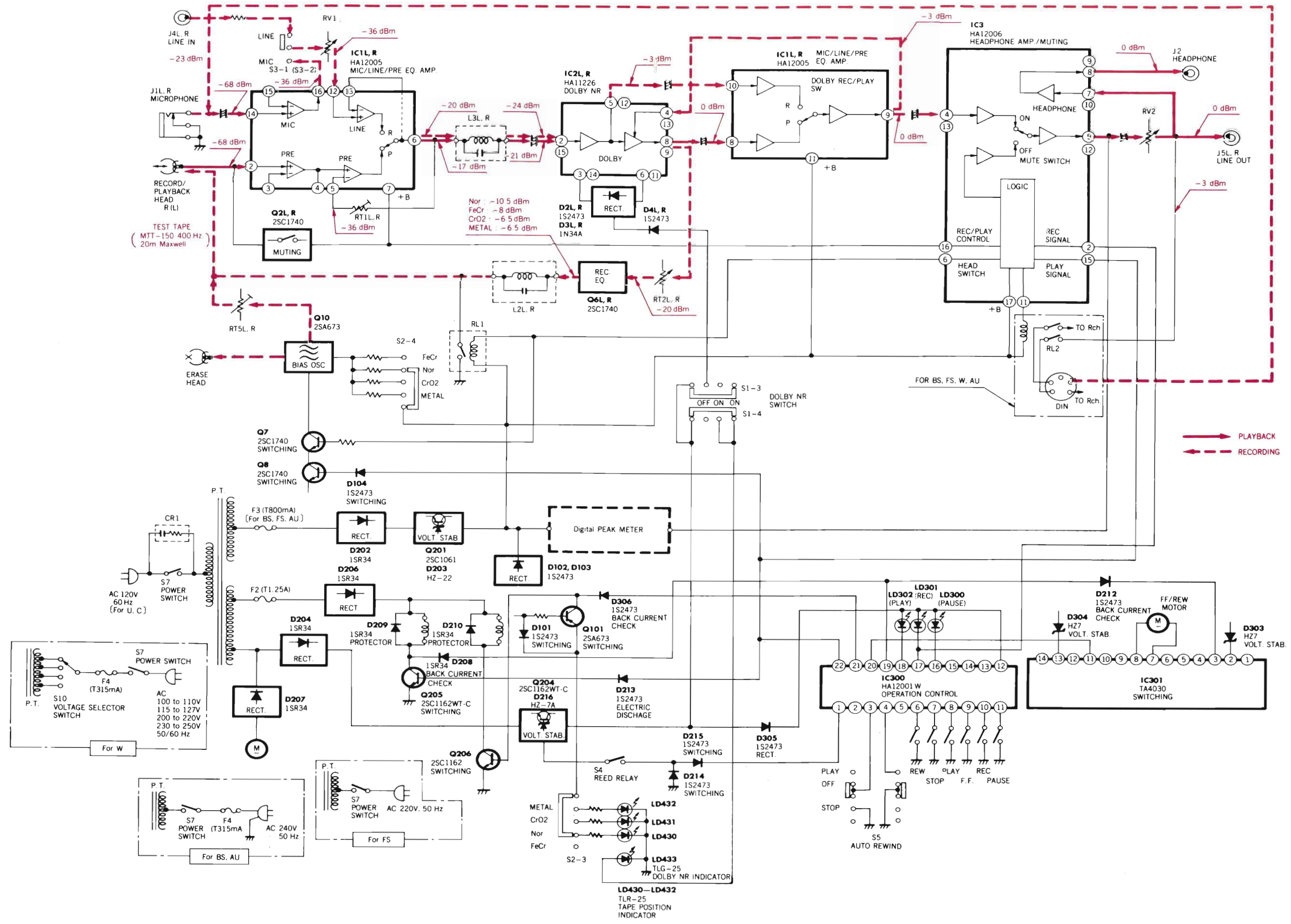
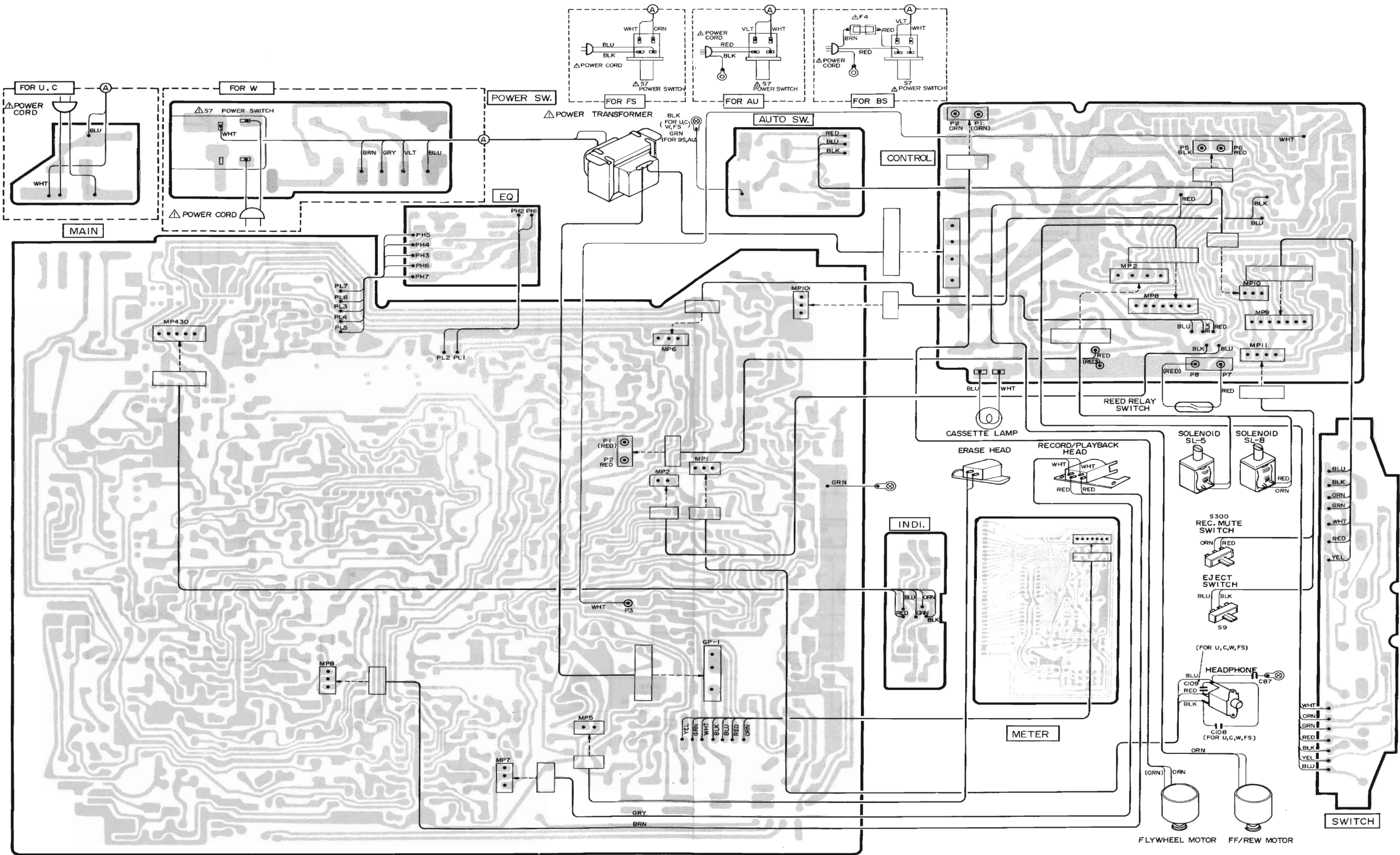

Fig. K

BLOCK DIAGRAM



WIRING DIAGRAM



CIRCUIT BOARD DIAGRAM

Ground : Signal, +B

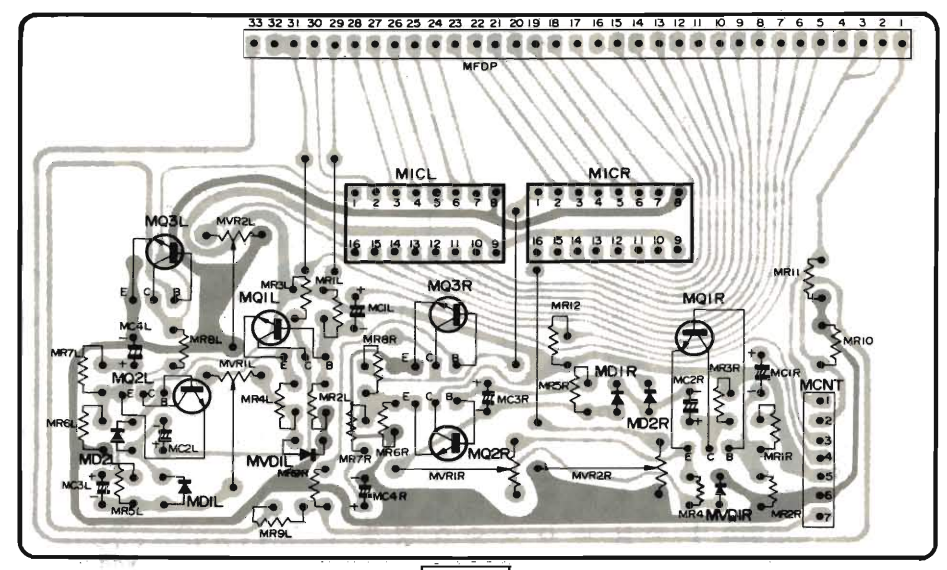
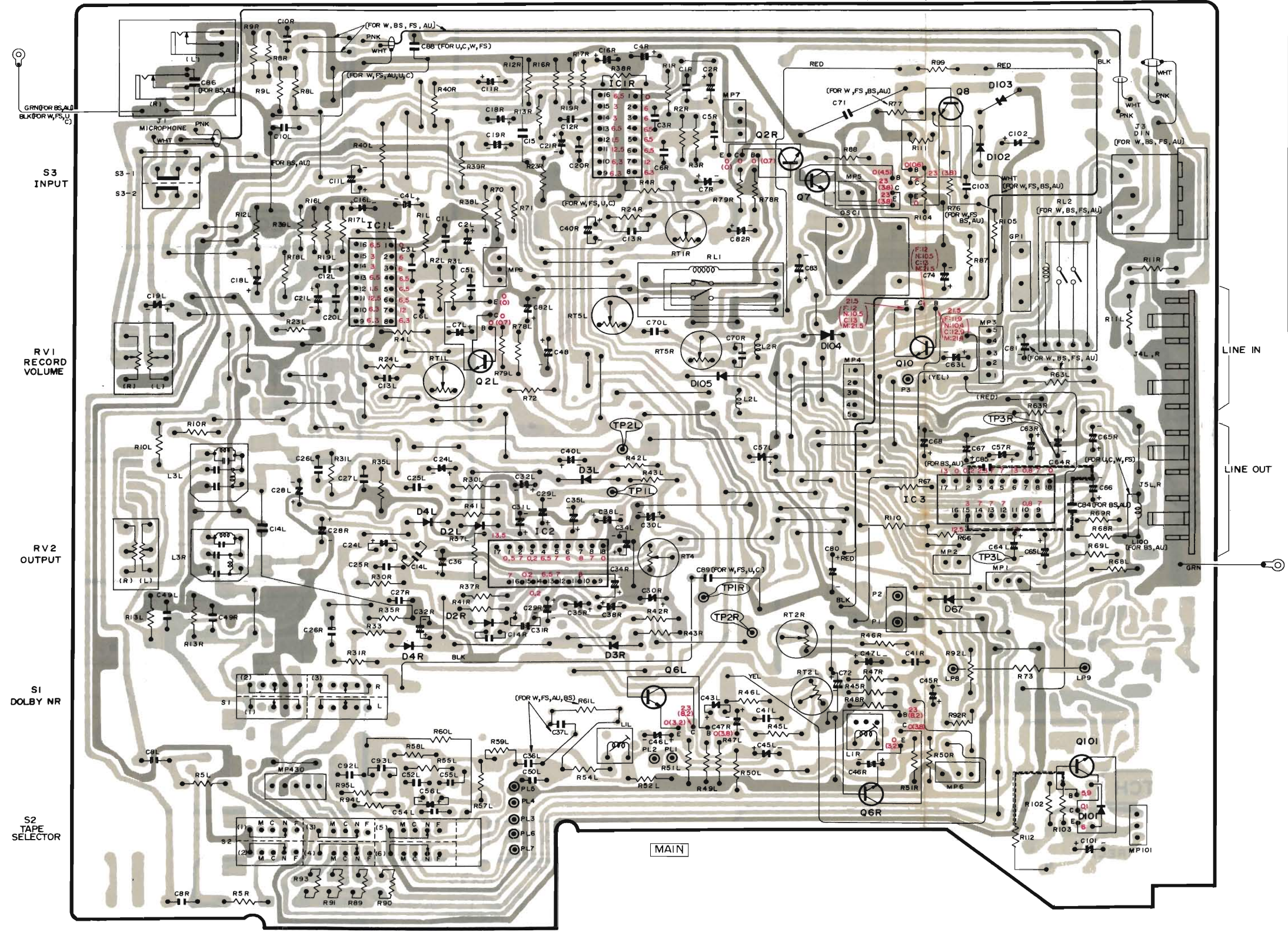

CIRCUIT BOARD DIAGRAM

Ground Signal, +B

CONTROL

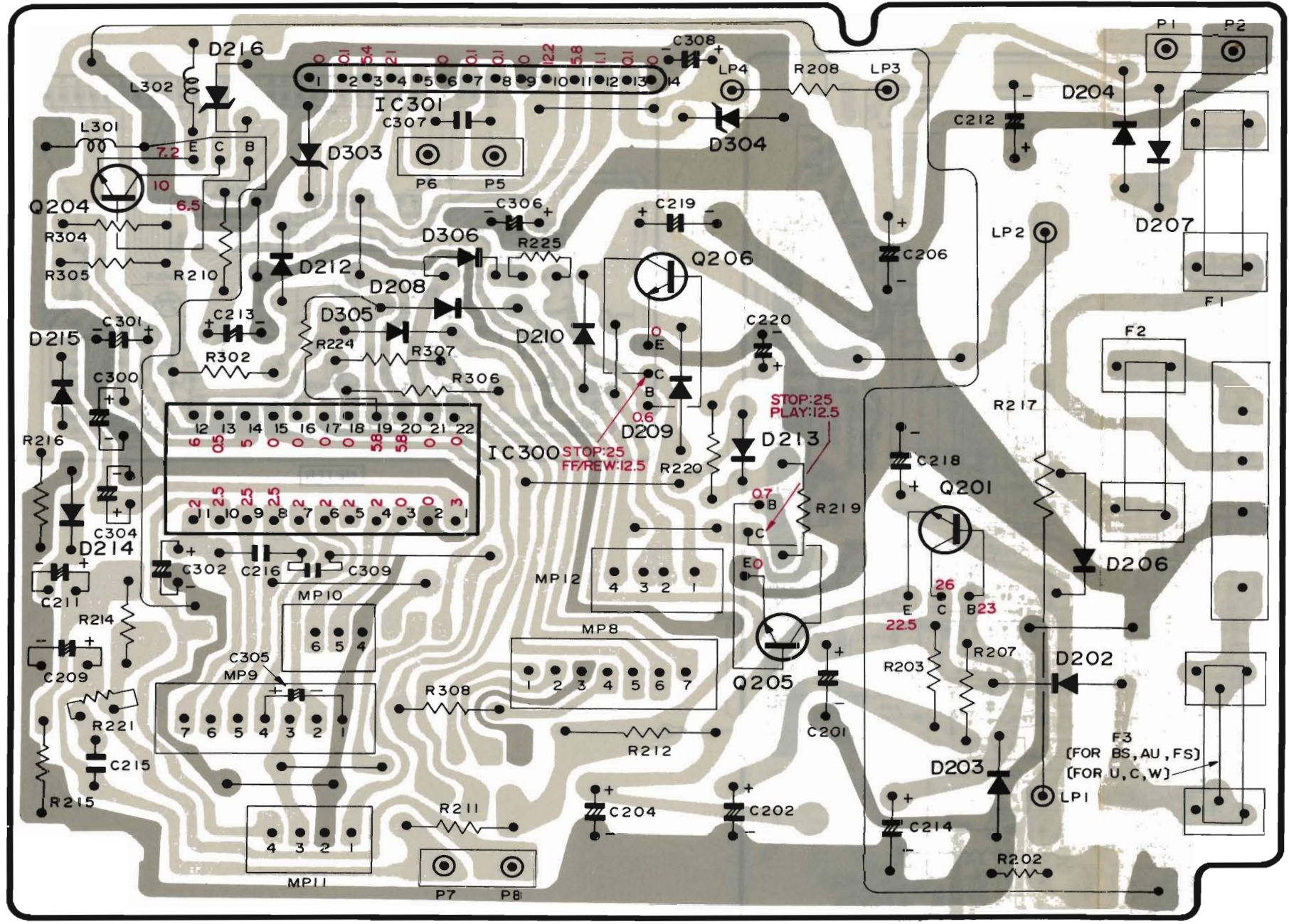

POWER (FOW W)

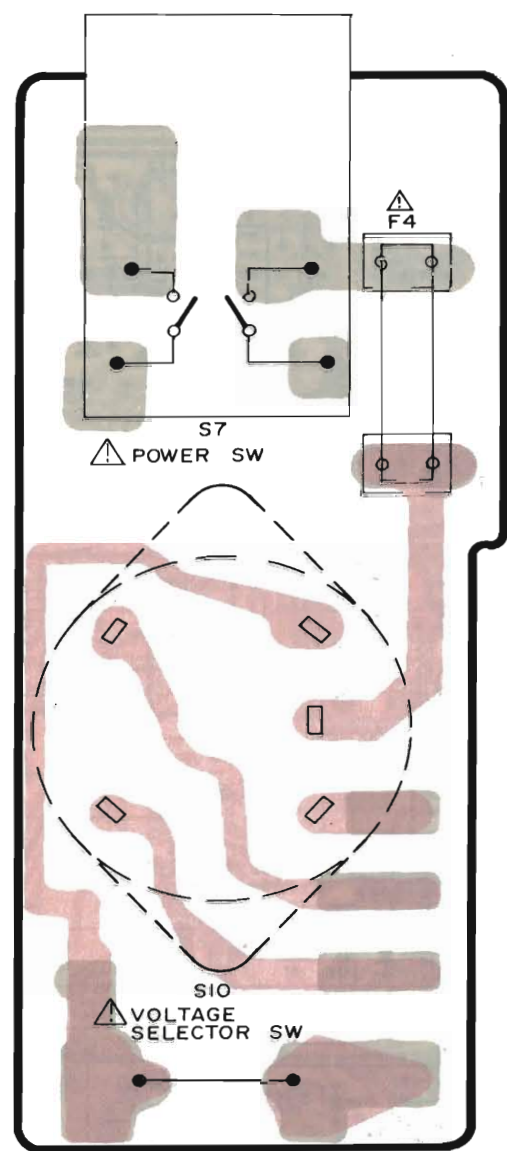

POWER SWITCH (FOR U, C)

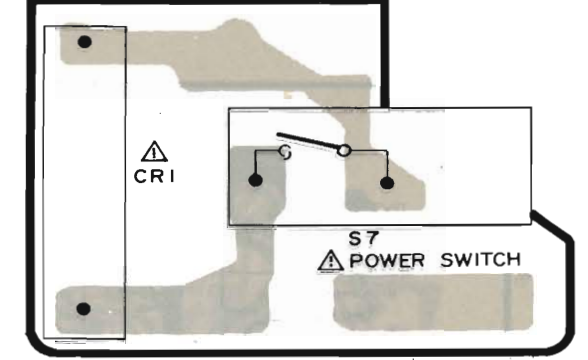

EQ.

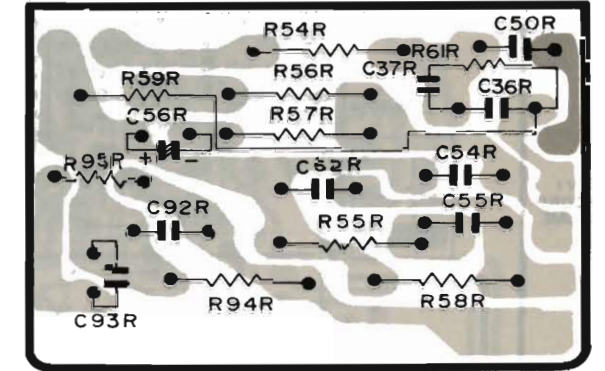

AUTO SW.

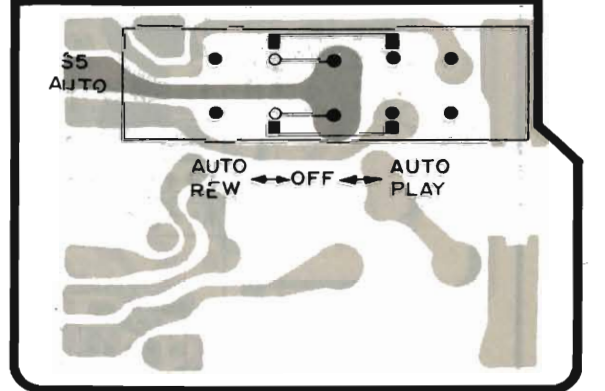

OPERATION SWITCH

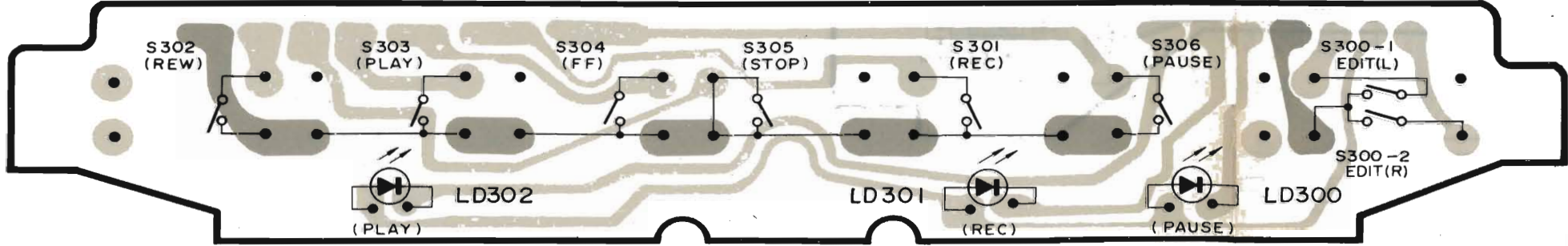

INDICATOR

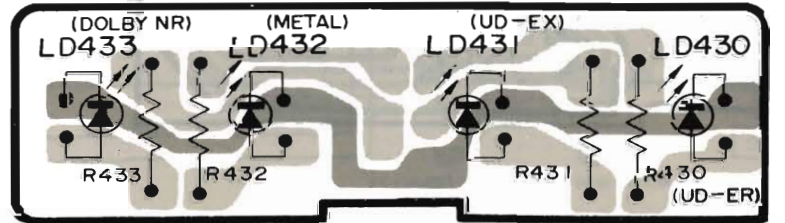

SCHEMATIC DIAGRAM

MVD1L,R VDI221
 MD1L,R IS188FM
 MD2L,R IS188FM
 MQ1L,R C1815Y
 MQ2L,R C1815Y
 MQ3L,R C1815Y
 M1CL,R BA658

IC3 HA12006 HEADPHONE AMP/MUTING
 DIO3 IS2473 RECT.
 DIO3 IS2473 RECT.
 LD430, LD431, LD432, LD433 TAPE POSITION INDICATOR

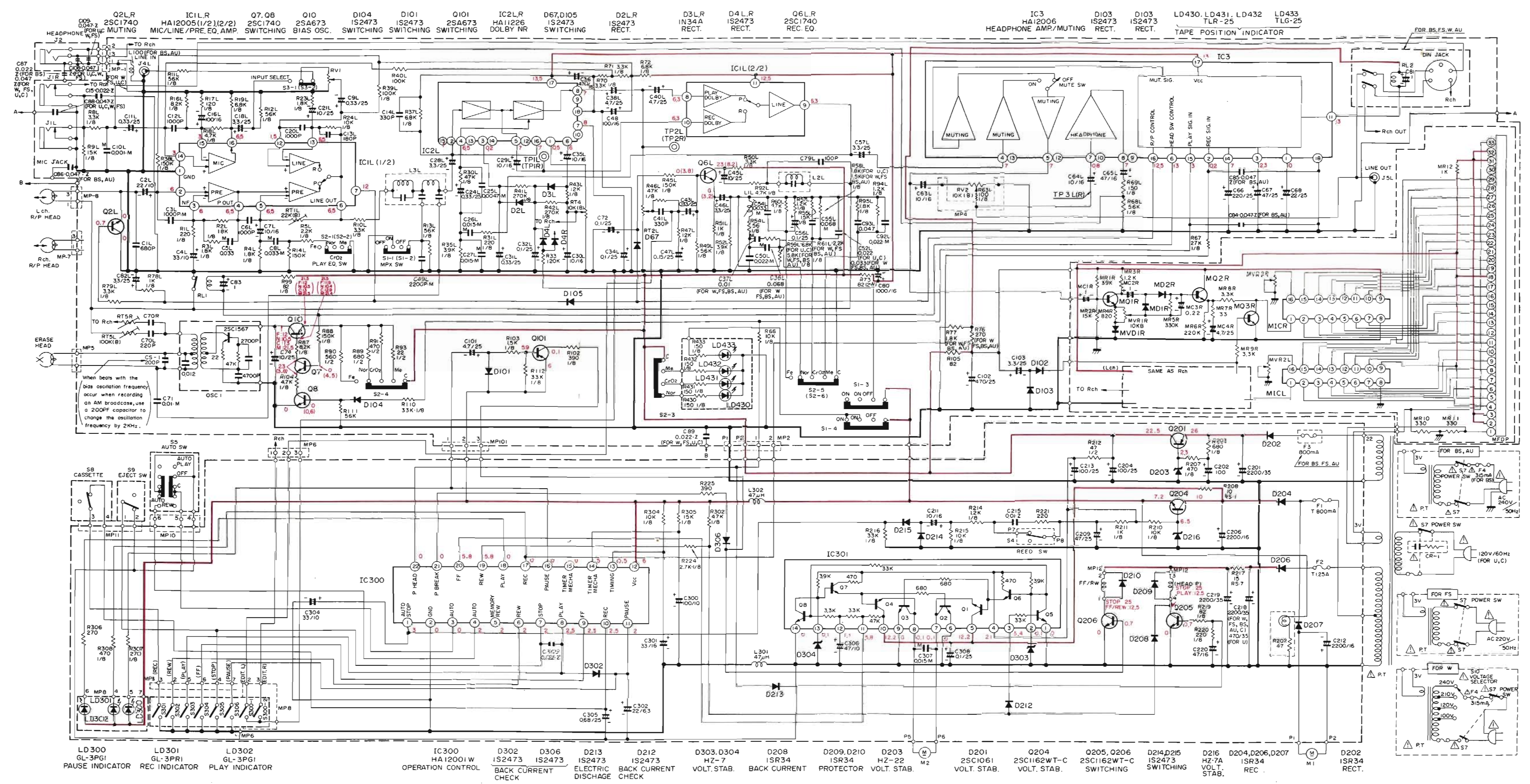

LD300 GL-3PG1 PAUSE INDICATOR
 LD301 GL-3PR1 REC INDICATOR
 LD302 GL-3PG1 PLAY INDICATOR
 IC300 HA12001W OPERATION CONTROL
 D302 IS2473 BACK CURRENT CHECK
 D306 IS2473 BACK CURRENT CHECK
 D213 IS2473 ELECTRIC DISCHARGE
 D212 IS2473 BACK CURRENT CHECK
 D303, D304 HZ-7 VOLT. STAB.
 D208 ISR34 BACK CURRENT
 D209, D210 ISR34 PROTECTOR
 D203 HZ-22 VOLT. STAB.
 D201 25C1061 VOLT. STAB.
 Q204 25C1162WT-C VOLT. STAB.
 Q205, Q206 25C1162WT-C SWITCHING
 D214, D215 IS2473 SWITCHING
 D216 HZ-7A VOLT. STAB.
 D204, D206, D207 ISR34 REC.
 D202 ISR34 RECT.

Note

1. Voltage measured at base of chassis with minimum volume control and no signal.
2. Nomenclature of Resistors and Capacitors.

		Circuit No.	
Value	No indicated	Ω (Ohm)	
	M	1000kΩ	
Tolerance	No indicated	±5%	
	K	±10%	
Wattage	No indicated	1/4W	
Sort	No indicated	Carbon film	
		RC : Composition RW : Wire wound RS : Oxide metal film RN : Fixed metal film	

		Circuit No.	
Value	No indicated	μF	
	P	Pf	
Tolerance	No indicated	±10%	
	J	±5%	
Sort			
Sort		Ceramic	
		Electrolitic	
Sort		Mylar	
		Polystér	
Sort		Styrol	
Voltage	No indicated	50WV	

3. Be sure to make your orders of resistors and capacitors with value, voltage, tolerance and sort.
4. When replacing capacitors marked with *, use specified ones stated on parts list since required temperature characteristics.

REPLACEMENT PARTS LIST

SYMBOL-NO	P-NO	DESCRIPTION	SYMBOL-NO	P-NO	DESCRIPTION
CAPACITORS					
C 2LR	0256402	TANTALUM ELECTROLYTIC 22MF 10V	Q 2LR	5321295	TRANSISTOR 2SC1740E
C 4LR	0256404	TANTALUM ELECTROLYTIC 33MF 10V	Q 6LR	5321295	TRANSISTOR 2SC1740E
RESISTORS					
△ CR1	0219902	CR PACK 120 OHM 0.0033MF 450V (For U)	Q 7	5321295	TRANSISTOR 2SC1740E
△ CR1	0219907	CR PACK (For C)	Q 8	5321295	TRANSISTOR 2SC1740E
R 73	0169056	WINDING 82 OHM±5% 2W	Q 10	5320593	TRANSISTOR SILICON 2SA673C 80M
RT 1LR	5007187	SEMI VARIABLE 22K OHM	Q101	5320593	TRANSISTOR SILICON 2SA673C 80M
RT 2LR	5007186	SEMI VARIABLE 10K OHM	Q201	5320671	TRANSISTOR SILICON 2SC1061B 5M
RT 4	5007186	SEMI VARIABLE 10K OHM	Q204	5320643	TRANSISTOR SILICON 2SC1162 150M
RT 5LR	5007189	SEMI VARIABLE 100K OHM	Q205	5320643	TRANSISTOR SILICON 2SC1162 150M
RV 1	5000556	VARIABLE 20K OHM(A)	Q206	5320643	TRANSISTOR SILICON 2SC1162 150M
RV 2	5000145	VARIABLE 10K OHM(B)	TRANSFORMERS		
R217	0112963	OXIDE METAL FILM 15 OHM±10% 7W	△ PT	5212642	POWER (For U)
SEMI-CONDUCTORS					
D 2LR	5330572	DIODE SILICON 1S2473HC 100M	△ PT	5212643	POWER (For C)
D 3LR	5330721	DIODE GERMANIUM 1N34A 10MHZ 50MW	△ PT	5212644	POWER (For FS)
D 4LR	5330572	DIODE SILICON 1S2473HC 100M	△ PT	5212645	POWER (For BS)
D67	5330574	DIODE 1S2473	△ PT	5212646	POWER (For W)
D101	5330574	DIODE 1S2473	△ PT	5212647	POWER (For AU)
D102	5330572	DIODE SILICON 1S2473HC 100M	COILS		
D103	5330574	DIODE 1S2473	L 1LR	5120274	CHOKER
D104	5330572	DIODE SILICON 1S2473HC 100M	L 2LR	5120562	TRAP
D105	5330571	DIODE 1S2473VE	L 3LR	5161661	DOLBY FILTER
D202	5331241	DIODE 1SR34	L301	5152125	CHOKER 47MICRO H
D203	5331013	ZENER DIODE H222	L302	5152125	CHOKER 47MICRO H
D204	5331241	DIODE 1SR34	MISCELLANEOUS		
D206-210	5331241	DIODE 1SR34	5310272	FL METER	
D212-215	5330572	DIODE SILICON 1S2473HC 100M	5310372	FL METER BLOCK	
D216	5330311	DIODE SILICON HZ7A 1.0M	△	5746157	POWER CORD (For W, FS)
D302	5330571	DIODE SILICON 1S2473	△	5746291	POWER CORD ASS'Y (For BS)
D303	5330313	DIODE SILICON HZ7C 1.0M	△	5746442	POWER CORD (For U, C)
D304	5330313	DIODE SILICON HZ7C 1.0M	△	5740653	POWER CORD (For AU)
D305	5330574	DIODE 1S2473	F1	5720175	FUSE 0.8A
D306	5330571	DIODE 1S2473VE	F2	5721063	FUSE 1.25AT
MICLR	5359691	IC BA658	F3	5720175	FUSE 0.8A (For FS, BS, AU)
IC 1LR	5350881	IC HA12005	△ F4	5720171	FUSE (For W)
IC 2LR	5350561	IC HA 11226	△ F4	5720171	FUSE (For BS)
IC 3	5350891	IC HA12006	J1LR	5674211	MIC JACK
IC300	5350852	IC HA12001W	J2	5674221	HEADPHONE JACK
IC301	5356981	IC TA4030	J3	5651141	5P DIN SOCKET (For W, FS, BS, AU)
LD300	5380242	LED GL 3PG1	J4LR	5676082	PIN JACK
LD301	5380241	LED GL 3PR1	J5LR	5676082	PIN JACK
LD302	5380242	LED GL 3PG1	OSC1	5260742	OSCILLATOR BLOCK
LD430	5380371	LED TLR-25	PL	5762035	POINTER LAMP
LD431	5380371	LED TLR-25	RL1	5641141	REED RELAY
LD432	5380371	LED TLR-25	RL2	5641141	REED RELAY (For W, FS, BS, AU)
LD433	5380372	LED TLG-25	S 1	5613311	SLIDE ROTARY SWITCH (DOLBY NR)
			S 2	5613322	SLIDE ROTARY SWITCH (TAPE SELECT)

EXPLODED VIEW

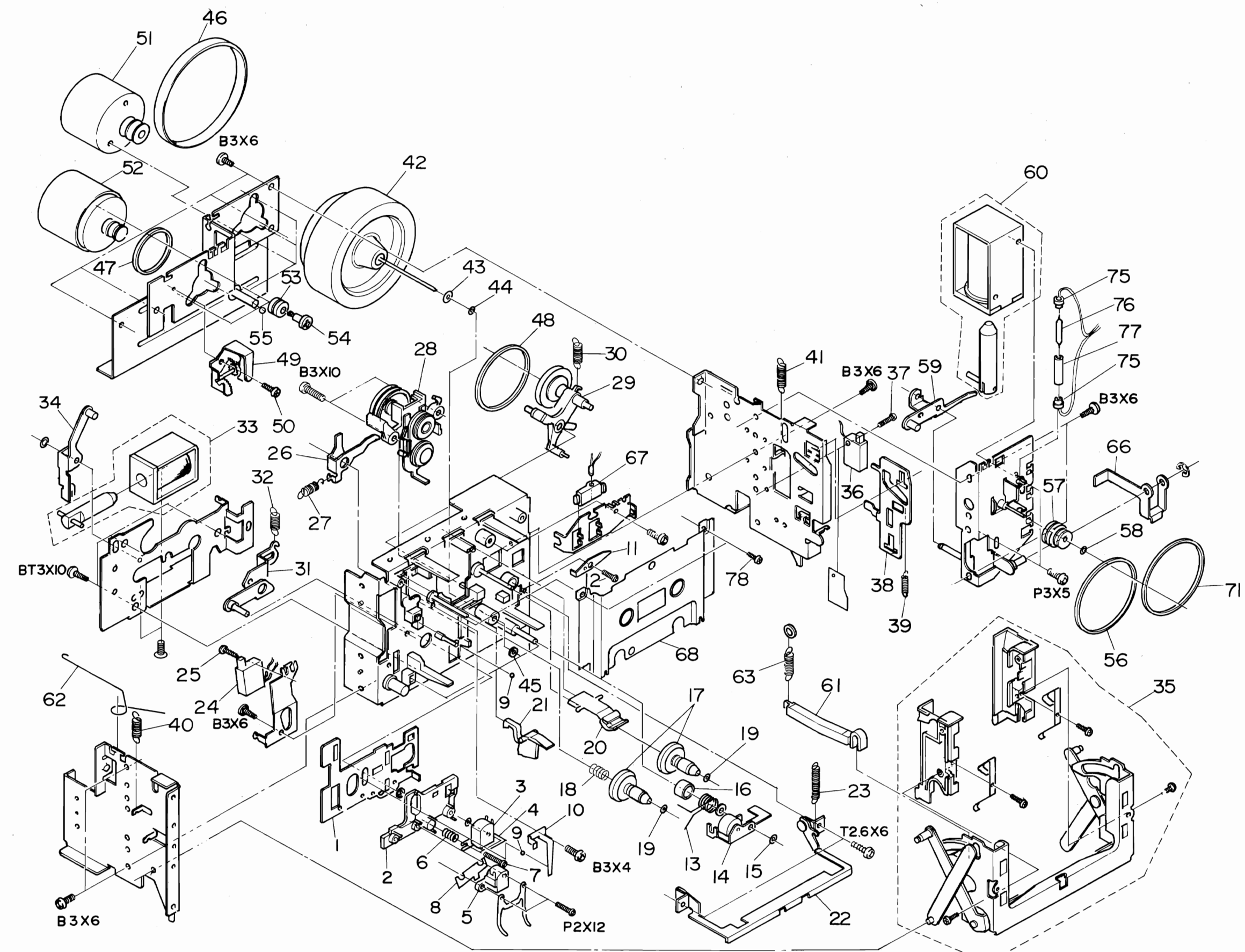

Note :
Components marked as Number in this drawing are not specified replacement parts.

REPLACEMENT PARTS LIST









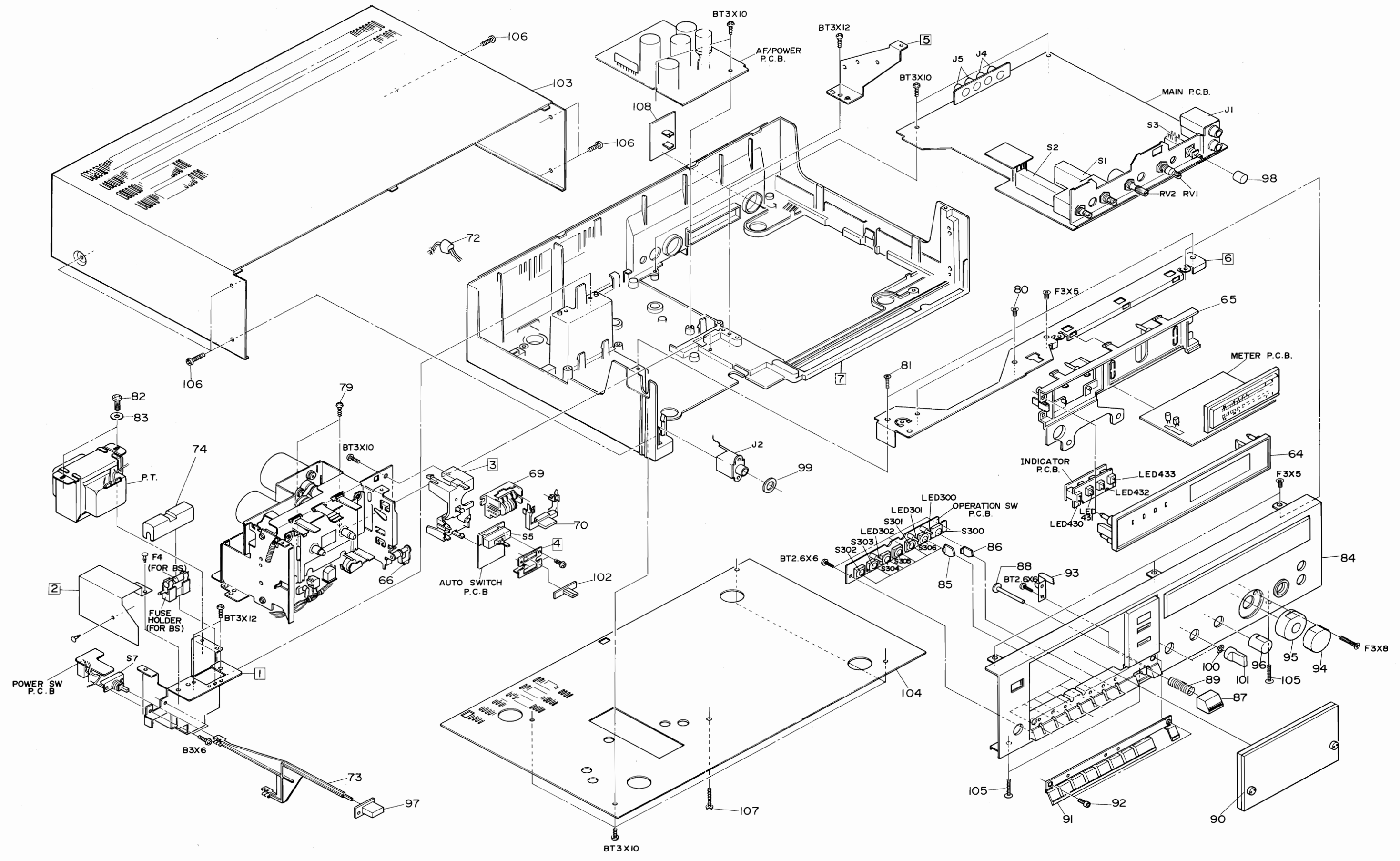

SYMBOL-NO	P-NO	DESCRIPTION	SYMBOL-NO	P-NO	DESCRIPTION
MISCELLANEOUS					
S 3	5634158	PUSH SWITCH (INPUT SELECT)	24	5633361	PUSH SWITCH
S 5	5620852	SWITCH-SLIDE (AUTO)	25	0671310	DT SCREW-2.6MMDX10MM
△ S 7	5633321	POWER SWITCH (For W)	26	7311952	BRAKE FUNCTION ARM
△ S 7	5633482	POWER SWITCH (For U, C)	27	6301022	SPRING
△ S 7	5633541	POWER SWITCH (For FS, BS, AU)	28	6413335	FF,REWIND BASE ASSEMBLY
△ S 10	5605081	ROTARY SWITCH (For W)	29	6413343	TAKE UP ARM ASSEMBLY
S300	5633371	PUSH SWITCH (EDIT)	30	6300982	SPRING
S301-306	5633352	PUSH SWITCH (REC, REW, PLAY, F.F., STOP, PAUSE)	31	7312511	PLAY ARM ASSEMBLY
FOR ACCESSORIES					
	5894164	PATCH CORD (For U, C, BS, AU)	32	6302375	SPRING
	5894165	PATCH CORD (For U, C, BS, AU)	33	5642512	SOLENOID ASSEMBLY (F.F,REWIND)
	5744843	DIN CORD (For W, FS)	34	7312103	FF,REWIND ARM ASSEMBLY
	7740321	HEAD CLEANING STICK	35	7312264	CASSETTE HOLDER ASSEMBLY
	5662021	SOCKET ADAPTER (For W)	36	5633361	PUSH SWITCH
FOR CASSETTE CHASSIS ASSEMBLY (A)					
1	7312092	HEAD PLATE	37	0671310	DT SCREW-2.6MMDX10MM
2	6753182	HEAD BASE	38	7312164	EJECT SLIDER
3	5444721	RECORD PLAYBACK HEAD	39	6306234	SPRING
4	5548351	HEAD TERMINAL P.W.B	40	6322213	SPRING
5	5445281	ERASE HEAD	41	6325084	SPRING
6	6321733	HEAD SPRING C	42	6373321	FLYWHEEL ASSEMBLY (R)
7	7781005	SCREW FOR HEAD MOUNTING	43	7772623	SPRING
8	7768181	HEAD SPACER	44	7786626	WASHER
9	0948492	BALL - 2MMD	45	7786623	POLY SLIDER WASHER
10	6532991	LEAF SPRING	46	6357147	FLYWHEEL BELT
11	7311982	ERASE STOP PLATE	47	6354702	BELT-29MMD
12	7536872	LOCK LEVER PIN	48	6354703	BELT-41MMD
13	6545232	SPRING	49	7290501	GOVERNOR
14	6383432	PRESSURE ROLLER ARM ASSEMBLY	50	0671305	DT SCREW-2.6MMDX5MM
15	7778856	POLYESTER WASHER	51	5576163	MOTOR ASSEMBLY (PLAY)
16	7575252	SPACER	52	5576151	MOTOR ASSEMBLY (F.F,REWIND)
17	6413313	TURNTABLE ASSEMBLY	53	6576084	RUBBER PLATE
18	6304031	SPRING	54	7539002	SCREW FOR MOTOR MOUNTING
19	7786115	POLYESTER WASHER	55	7768682	THRUST SUPPORT
20	6752853	CASSETTE HOLDER SPRING	56	6354792	COUNTER BELT
21	6752872	RECORD PREVENTION ARM	57	6346282	COUNTER PULLEY ASSEMBLY
22	7312281	CASSETTE UP ARM ASSEMBLY	58	7786115	POLYESTER WASHER
23	6301795	SPRING	59	7312113	PLAY ARM ASSEMBLY
			60	5642396	SOLENOID ASSEMBLY (PLAY)
			61	6753012	EJECT ARM ASSEMBLY
			62	6545265	DAMPER WIRE
			63	6540011	DAMPER SPRING

REPLACEMENT PARTS LIST

SYMBOL-NO	P-NO	DESCRIPTION	SYMBOL-NO	P-NO	DESCRIPTION
FOR CASSETTE CHASSIS ASSEMBLY (B)			85	6753071	FUNCTION BUTTON (RAUSE, REC, STOP, F.F., REW, PLAY)
64	6222731	FILTER PANEL ASSEMBLY	86	6753081	FUNCTION BUTTON (REC MUTE)
65	6754771	METER HOLDER	87	6051521	EJECT BUTTON
66	7312341	EJECT LEVER	88	6753111	BUTTON PIN
67	6574321	LAMP HOLDER	89	6304181	BUTTON SPRING
68	6631383	CASSETTE METAL ASSEMBLY	90	6092036	CASSETTE DOOR ASSEMBLY
69	5559234	COUNTER	91	6671522	FUNCTION METAL
70	6753282	COUNTER BUTTON	92	7781832	SPECIAL BOLT
71	6354633	COUNTER BELT	93	7451251	EARTH SPRING
△ 72	6794081	BUSHING (For U, C)	94	6287591	KNOB ASSEMBLY (RECORD L)
△	6794141	BUSHING (For W, FS)	95	6289181	KNOB ASSEMBLY (RECORD R)
△	6794161	BUSHING (For BS)	96	6287611	KNOB ASSEMBLY (OUTPUT)
△	6711351	BUSHING (For AU)	97	6051531	POWER BUTTON
73	6753821	SWITCH LEVER	98	6051272	PUSH BUTTON (INPUT SELECT)
△ 74	6742651	FUSE COVER (For BS)	99	7787161	WASHER
75	6576271	RELAY CAP	100	7787394	WASHER
76	5641092	REED RELAY	101	6287621	KNOB (TAPE +DOLBY NR)
77	7575542	TUBE	102	6296701	KNOB (AUTO REWIND)
78	7780915	BIND TAPPING SCREW-2MMDX5MM	103	6041601	UPPER COVER (For U, C)
79	8699412	BIND TAPPING SCREW-3MMDX12MM (BLACK)		6040767	UPPER COVER (For W, FS, BS, AU)
80	8724406	FLAT SCREW-3MMDX6MM	104	6040753	BOTTOM COVER (For U, C, FS, BS, AU)
81	7781581	BT FLAT SCREW-3MMDX10MM		6040754	BOTTOM COVER (For W)
82	8671608	DT SCREW-4MMDX8MM	105	7781583	BT FLAT SCREW-3MMDX14MM
83	7174533	WASHER	106	8699610	BT BIND SCREW-4MMDX10MM (For U, C)
MISCELLANEOUS				7781731	BT BIND SCREW-4MMDX10MM (For W, FS, BS, AU)
84	6222282	FRONT PANEL ASSEMBLY (For U, C)	107	8691425	BT BIND SCREW-3MMDX25MM
	6222283	FRONT PANEL ASSEMBLY (For W, FS, BS, AU)	108	6754292	DIN CAP (For U, C)

EXPLODED VIEW



Type of head			
P	Pan head screw		BT Binding head tapping screw 
F	Flat countersunk head screw		BL Bolt 
B	Binding head screw		W Washer 
T	Round head tapping screw		E "E" ring 
Length (L mm)			
Diameter (D mm)			

When ordering hardware excluding stated on these lists, be sure to make your orders with type and size.

HITACHI SALES CORPORATION OF AMERICA
Eastern Regional Office
 1200 Wall Street West, Lyndhurst, New Jersey 07071
 Tel. 201-935-8980
Mid-Western Regional Office
 1400 Morse Ave., Elk Grove Village, Ill. 60007
 Tel. 312-593-1550
Southern Regional Office
 510 Plaza Drive College Park, Georgia 30349
 Tel. 404-763-0360
Western Regional Office
 401 West Artesia Boulevard, Compton, California 90220
 Tel. 213-537-8383
HITACHI SALES CORPORATION OF HAWAII, INC
 743-G Waiakamilo Rd., Honolulu, Hawaii 96817
 Tel. 808-841-0431

HITACHI SALES CORP. OF CANADA Ltd.
 3300 Trans Canada Highway Pointe Claire, Quebec, H9R1B1, Canada
 Tel. 514-697-9150

HITACHI SALES EUROPA GmbH
 2 Hamburg 54, Kleine Bahnstraße 8, West Germany
 Tel. 850 60 71-75
HITACHI SALES (U.K.) Ltd.
 Hitachi House, Station Road, Hayes, Middlesex UB3 4DR, England
 Tel. 01-848-8787 (Service Centre : 01-848-3551)
HITACHI SALES SCANDINAVIA AB
 Rissneleden 8, Sundbyberg, Box 7138, S-172-07 Sundbyberg 7,
 Sweden
 Tel. 08-98 52 80
HITACHI SALES NORWAY A/S
 Oerebekk 1620 Gressvik P.O. Box 46 N-1601 Fredrikstad, Norway
 Tel. 032-28050
SUOMEN HITACHI OY
 Box 151, SF-15100 Lahti 10, Finland
 Tel. Lahti 44 241
HITACHI SALES A/S
 Kuldysen 13, DK-2630 Taastrup, Denmark
 Tel. 02-999200
HITACHI SALES A.G.
 5600 Lenzburg, Switzerland
 Tel. 064-513621
HITACHI-FRANCE (Radio-Télévision Electro-Ménager) S.A.
 9, Boulevard Ney 75018, Paris, France
 Tel. 201-25-00
HITACHI SALES WARENHANDELS GMBH
 A-1180/Wien, Kreuzgasse 27
 Tel. (0043222) 439367/8



HITACHI SALES AUSTRALIA Pty Ltd.
 153 Keys Road, Moorabbin, Victoria 3189 Australia
 Tel. 95-8722

HITACHI Ltd. TOKYO JAPAN
 Head Office : 5-1, 1-chome, Marunouchi, Chiyoda-ku, Tokyo
 Tel. Tokyo (212) 1111 (80 lines)
 Cable Address : "HITACHY" TOKYO
 Codes : All Codes Used